



1. Turn off all power to the boiler at the circuit breaker.
This will avoid accidental injury, or short circuits.
2. All connections are 24 volt AC. Verify all planned connections at TT thermostat connections, before turning on power
3. Locate and attach Exquisite Heat control box in a safe dry elevated location. Do not attach controller to boiler. This may be a source of water damage. Consider the wiring runs from the boiler, the location of 24 volt power to the control source, and the convenience of service and adjustment with lap top computer. The lighted signals from the control box should be visible to any one entering the boiler room. This way you can do telephonic diagnostics for scheduling service.
4. Install thermostatic 6 wire 18 gauge cable from the boiler to the control box. Leave plenty of extra wire for final wiring to the boiler and the control.
5. Make sure all boiler cut off wiring is in series with 24 VAC safety control circuit to insure fail safe control. Test all safety control operation in order to insure they are in good working order.
6. Feed a two wire thermostat cable to the TT jumper on the Oil burner assembly or in series with the 24 volt power to the gas valve. Secure to the existing cable to the burner control module.

Alternative wiring.

Thermostat activity will be connected to the computer from TT relay.

Make sure the thermostat NO relay terminals are used to avoid circuit conflicts.

If 24 volts come from the thermostat, use the wiring on page 1.

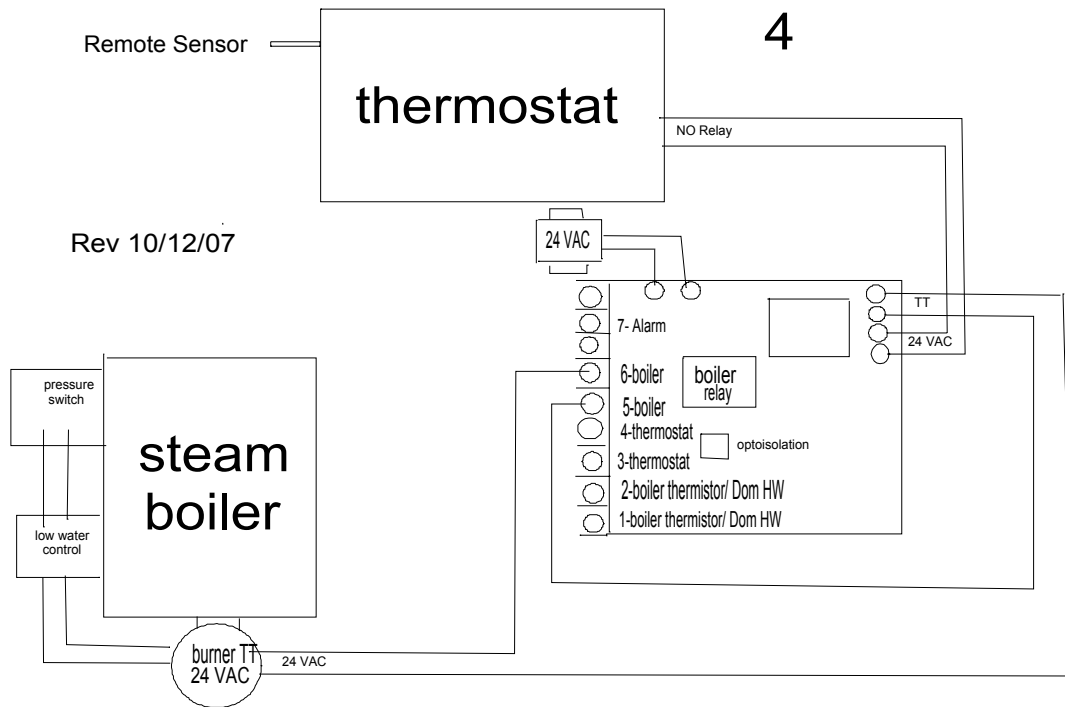

Make sure all boiler connections are in series with 24VAC safety circuit. Test all safety devices to insure their proper activation in case of failure.

Be sure to leave enough slack in order to facilitate burner service and maintenance. Keep wires secure away from high heat during burner operation. Remove the oil burner TT jumper wire and attach two wire cable to TT on the burner control. For gas models attach wires in series with 24 volt gas valve actuator circuit. Connect this wire to the **blue and white wires** in the thermostat 6 cable.

7. Attach two wire thermostat cable to the TT low voltage connection on the boiler relay in parallel for analysis of thermostat demand. Secure this cable back to the 6 wire thermostat cable and attach to **red and green wires**. Use appropriate wire nuts or pressure fasteners to secure all connections at this point. The remaining wires are available for domestic hot water application if needed.
8. For domestic hot water applications in the event that a tankless coil or separate storage tank is used attach a thermistor and secure to the hot supply side near the boiler going to the storage tank. In the case of a tankless coil, place the sensor on the tankless out pipe to the house, near the tankless coil exit (**hot side**). Dress this wire back to the 6 wire thermostat cable.
9. Neatly dress the wires, to avoid heat which could damage wire insulation, any flue pipes, over any piping that could be serviced at a later point, away from high voltage lines that could create interference with control signals, and secure to avoid fouling with other systems in the area.
10. Check and recheck all wires, connections, and colors of connections. Make sure all sensors are secure, and insulation. Fasten the wire harness after the full installation is completed and working properly. Triple check all wiring and connections to avoid a call back. If you use a standardized installation procedure, you will reduce trouble calls and the need to revisit the site.
11. Place the wires to the controller through the box openings provided for convenient wiring within the box. Estimate the wire lengths needed for the control and prepare your wire stripping for final control wiring. Attach your wiring:
 - A. Attach the 24 volt TT wires from the circulator relay (**red & green**) to the Thermostat current Opt coupler connections at “OPTO” terminals.
 - B. Attach the Boiler Cut Off wires from TT on the burner (**Blue & White**) to the “CUT OFF” terminals.
 - C. If used attach the Domestic Hot water thermistor wires to the “**VR 2**” terminals. Place the sensor on the out pipe from the boiler . The sensor need to know the boiler temperature as the domestic hot water leaves the boiler for the hose or the indirect heater.
 - D. Attach 24 volt AC transformer wires to “**24VAC**” . The middle connector is not used. This provides distance between connection to avoid short circuits when making connections.
 - E. If required attach “NO or NC” connections to the “ALARM” terminals. The center terminal is common. This relay can be used with a local light, alarm system, or local bell. External power must be provided to operate alarm circuit. This relay is simply a No or NC Relay when the boiler temperature sensor goes above the High Safety set in Menu or below the Low Temp Safety set in menu. The use of the alarm relay is optional.

- F. Some models come with a 9 Volt DC transformer and input which is available on some earlier models.
 - G. For four wire electronic thermostats 24 volt AC is available by attaching the power wires for the thermostat to the “24VAC” terminals.
Thermostat wires needing 24 VAC are attached at the relay. (see drawing 3 below)
If The thermostat signal is 24 VAC (see drawing 4 below.)
 - H. Connect and install the **turn off** switch in series with your 24vlot AC power supply.
This is provided to disconnect the control from the heating system in case of system failure or loss of heat. When disconnected this switch removes power to the control and returns the heating system to previous mechanical. (cut off relay closes on spring when power is removed.) If the heating system is not operating after the switch is off, call the heating service for the boiler. Be sure your service sticker is on the face of the control. Be careful not to block good visibility of the lights within the control box.
12. For custom programming, attach the RS 232 cable to the cable connection on the Board.
Attach the other end of the RS 232 cable to the Lap top cable out.
 13. Recheck all wiring.
 14. Power up the Boiler at the Circuit breaker.
 15. Power up Exquisite Heat.
 16. Turn on the Boiler service switch. Check for thermostat polarity (yellow light one when thermostat when thermostat is calling for heat. This polarity may be adjusted in terminal mode or by Removing **J-2 jumper** on the board.
You can also provide for Cold Start for boilers not heating domestic hot water. To accomplish **cold start operation, remove J-1 jumper**. Cold start will allow boiler to rest if thermostat activation does not occur above 10% activity during the previous analysis period. This allows for boiler resting on warm days and summer season.
 17. Activate Exqheat Terminal program on the lap top.
 18. Type “menu” Enter. You now have the ability to edit all parameters which you received at the factory training session. All limits can be adjusted. Refer to your programming manual for proper adjustment.
 - 19 For further guidance call your area supervisor or the factory at 914-588-4791. You can e-mail service at Exqheat@prodigy.net with your inquiries.
 20. When finished, remove the terminal cable from the control box and fix the controller onto the standoff lugs provided.

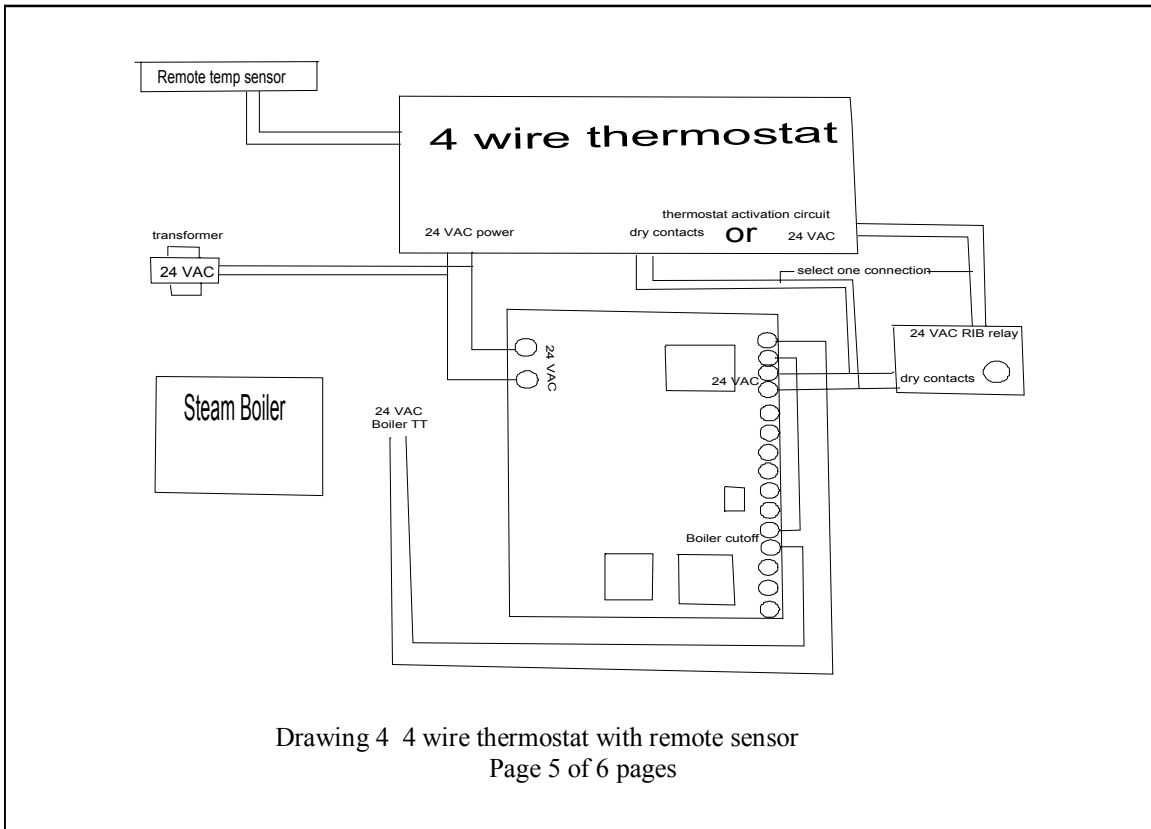
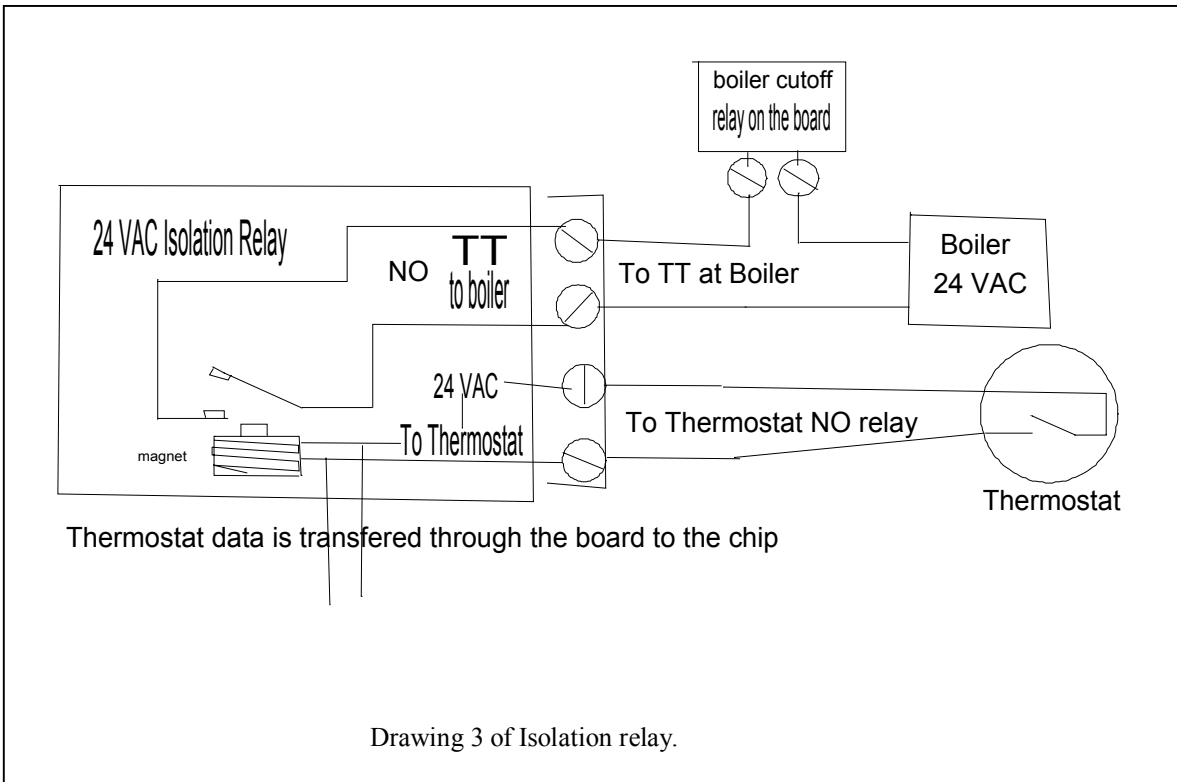

Limited Five-Year Warranty

The seller warrants its product against defects in material or workmanship for a period of 5 years from the date of manufacture. The liability of the seller is limited, at its option, to repair, replace or issue a non-case credit for the purchase prices of the goods which are provided to be defective. The warranty and remedies set forth herein do not apply to any goods or parts thereof which have been subjected to misuse including any use or application in violation of the Seller's instructions, neglect, tampering, improper storage, incorrect installation or servicing not performed by the Seller. In order to permit the Seller to properly administer the warranty, the Buyer shall: 1) Notify the Seller promptly of any claim, submitting date code information or any other pertinent data as requested by the Seller. 2) Permit the Seller to inspect and test the product claimed to be defective. Items claimed to be defective and are determined to be by the Seller to be non-defective are subject to a 60.00 per hour inspection fee. This warranty constitutes the Seller's sole liability hereunder and is in lieu of any other warranty expressed, implied or statutory. Unless otherwise stated in writing, Seller makes no warranty that the goods depicted or described herein are fit for any particular purpose.