

Materials: 8 wire thermostat cable according to location of points.
Other 4 wire and 2 wire thermostat cable as needed.
Pipe wrap insulation. Cable ties for wiring.

Place the control box (supplied) on a wall near the boiler. Feed the wires through the control box holes provided.

#1. Thermostat low voltage connection. A two wire thermostat cable (red and green) to thermostat parallel connection with the thermostat at TT on the aquastat, low voltage side (see drawing at end of this document). If the circuit is a partial drain to digital or programmable thermostat or boiler control, you may have to isolate the thermostat circuit from the boiler with isolation relay #9 provided on the board. This isolation circuit is for desired thermostat analysis. If the thermostat information is distorted the analysis will be inaccurate. This means that there are two sources of thermostat information. One from the opt coupler connections #1 (red and green wires) or from the isolation relay #9.

10/1/08

Page 1 of 5 pages

#2. In series to low voltage Control Circuit connection at TT jumper on the Burner Control. Two wire thermostat cable (blue and white) to enter the boiler safety series circuit in series. This is a disconnect relay circuit to interrupt the boiler fire cycle at Exqheat High Set Point temperature. Be careful not to defeat the safety circuit. You want to be in a low voltage 24 vac control circuit only. On gas valves attach in series with 24 volt going to the gas valve.

#3. Two wire thermostat cable (yellow and black) for thermistor (supplied) to the top of the boiler against the supply hot water feed pipe, just above the boiler cabinet. Wrap with insulation and secure with wire ties. This will measure the temperature of the boiler water and enable the control to shut off at the calculated High Limit and turn the boiler on at Low limit. The differential is set in software at 15 degrees F to avoid short cycling the burner.

#4. 24 VAC (Volt Alternating Current) input from 40 VA (Voltage Amperes) transformer located on zone control , boiler, or independent transformer. A plug in 24VAC 40VA transformer can be used as well.

#5. RS 232 connection to terminal mode on Laptop Computer. The menu allows changing of all variables to suit the installation. This requires laptop training from local distributor or factory training.

All variables in the control can be programmed at the factory. See details on the software settings order sheet word document on the “How to do it” page. You can have (if dealer) a local lap top access to change settings of limits, etc. (see Operation page at www.Exqheat.com).

Be sure to conduct work according to all Local and National Codes. Use Licensed Mechanical Contractors and Electricians where required.

#6 A normally open or closed relay is available for connection to security system zone, local bell, or telephone dialer. This alarm trigger is actuated when temperatures reach preset High 220 degrees F , or low safety 50 degrees F.. This has many applications. In the event of an alarm the control resets to start up temperature 150 degrees.

#7. Computer indicator light. Normally flashing green Led (Light emitting diode) on and off every second. This indicates that the computer is in good operating mode. At start up application of power a one minute delay is indicated by three rapid flash light sequence.

The delay is provided in order to avoid start up after power outage. It is also available to let service personnel see the boiler start up to 150 degrees F. The delay avoids false starts from intermittent power surge. At the end of the delay the computer goes on line, the boiler should start, and the system will respond to thermostat activity and temperature demand.

#2. Boiler relay is a disconnect relay. When the boiler is to be on the Red Led (Light emitting Diode) is out. When the boiler reaches the calculated Exquisite Heat high limit the relay will disconnect the series circuit 24 volt Burner circuit and the burner will stop firing. (red light ON) When the temperature reaches the low limit the relay will engage. (red Led will go out) When Led is lit the boiler should be off. When the Led is out the boiler can fire. If power is withdrawn (off switch on the box or wall transformer disconnect) from the control the relay springs back to the ON (closed) position. This will allow the boiler to operate on factory controls. When service personnel are in doubt as to what the trouble would be in a "no heat" situation, they can turn off the power switch to the control. The boiler should start. If the boiler does not start, the boiler fuel and operation should be checked. After the boiler is fixed the control can be switched back on and will take the boiler to start up after the one minute surge delay.

#10. To insure good thermostat data from different thermostat configurations this middle Yellow Led will go on when the thermostat is calling for heat. If the light does not react to thermostat activation and deactivation, changes must be made in Menu mode to change the polarity of the signal being received from the thermostat circuit. Change in polarity can also be effected by removing jumper #10

Several activations and deactivations of the thermostat must be confirmed from the actual thermostat in the room, in order to assure good thermostat data for analysis at the end of the analysis period. If the light does not respond to both activation (on) and deactivation (off), there is stray voltage in the circuit and isolation of the thermostat must be made with rewiring to the isolation relay #9. Retest Yellow Led for light on when thermostat activated.

#12 Domestic hot water supervision is available at jumper #12. If removed the domestic hot water will be maintained between 130 and 140 degrees at the supply pipe where the second thermistor 12 (orange and brown wires) is attached to the domestic hot water piping. This location is usually on the return side to the boiler. Individual system requirements will determine the proper location. Caution should be taken to avoid high scalding temperatures to the outlets, and Legionella risk from too low temperatures below 120 degrees.

Check you local Authority with Jurisdiction for requirements.

10/1/08

1

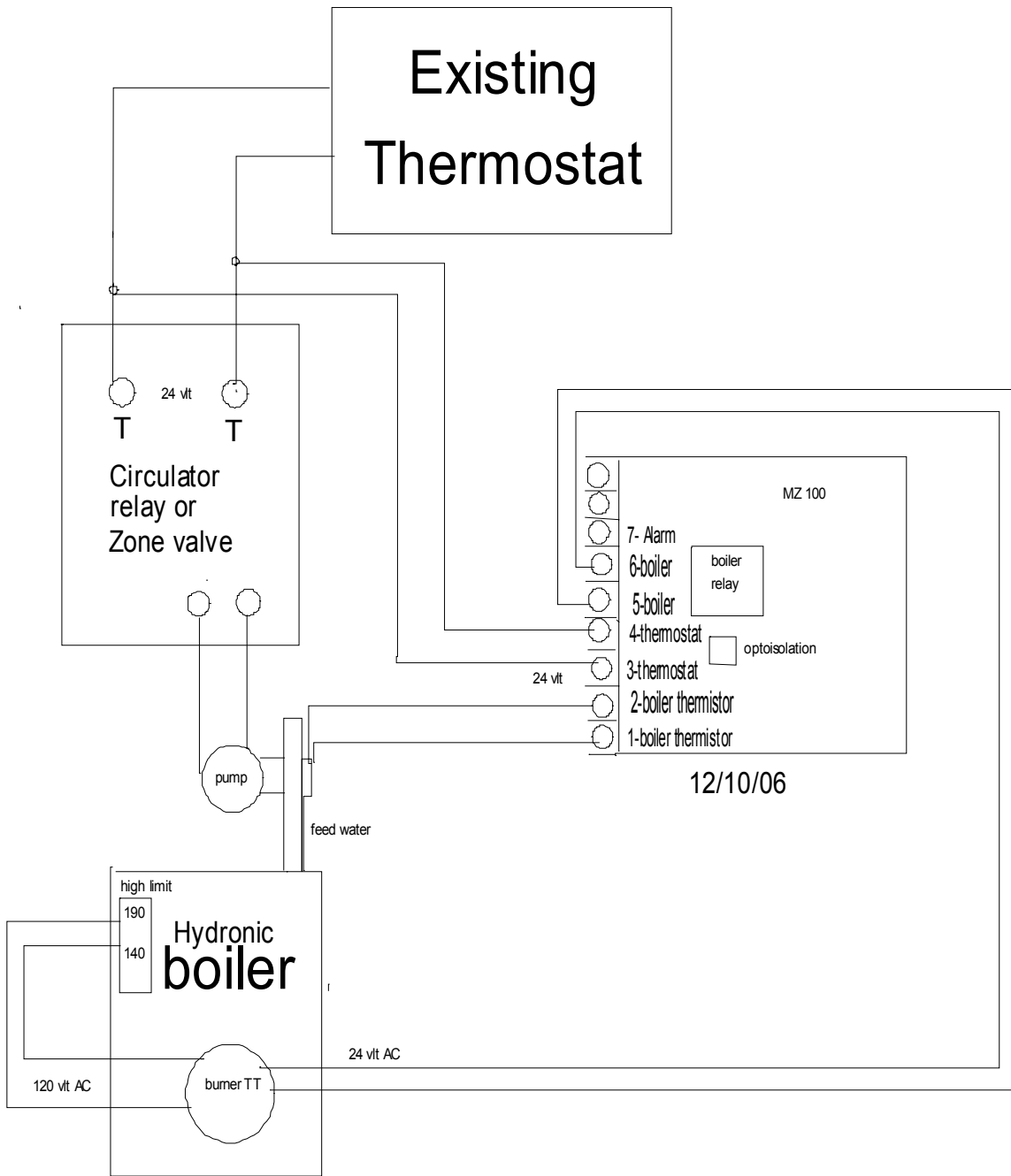

Factory settings sheet is available on the web page. It cannot be copied from this PDF file. You can open a word document on the how it works page and then make changes and e-mail, or print and mail.

Limited Five-Year Warranty

The seller warrants its product against defects in material or workmanship for a period of 5 years from the date of manufacture. The liability of the seller is limited, at its option, to repair, replace or issue a non-case credit for the purchase prices of the goods which are provided to be defective. The warranty and remedies set forth herein do not apply to any goods or parts thereof which have been subjected to misuse including any use or application in violation of the Seller's instructions, neglect, tampering, improper storage, incorrect installation or servicing not performed by the Seller. In order to permit the Seller to properly administer the warranty, the Buyer shall: 1) Notify the Seller promptly of any claim, submitting date code information or any other pertinent data as requested by the Seller. 2) Permit the Seller to inspect and test the product claimed to be defective. Items claimed to be defective and are determined to be by the Seller to be non-defective are subject to a \$60.00 per hour inspection fee. This warranty constitutes the Seller's sole liability hereunder and is in lieu of any other warranty expressed, implied or statutory. Unless otherwise stated in writing, Seller makes no warranty that the goods depicted or described herein are fit for any particular purpose.

Rev 10/1/08 JC

Further information is available at www.Exqheat.com or call 914-588-4791.